

SHAFT TYPE

OEK Model



Low Pulse Model

- Robust Encoder with Flange.
- Water Drip-Proof Bearing Type



Model

OEK- [] - [] - [] -050-00E

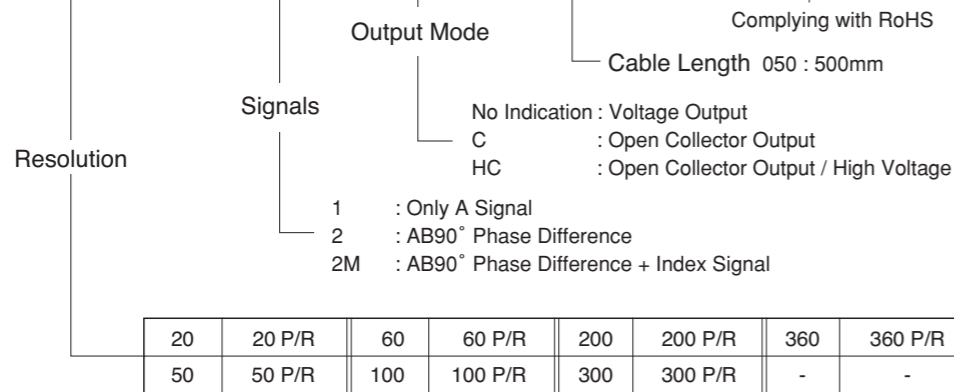

External Dimension

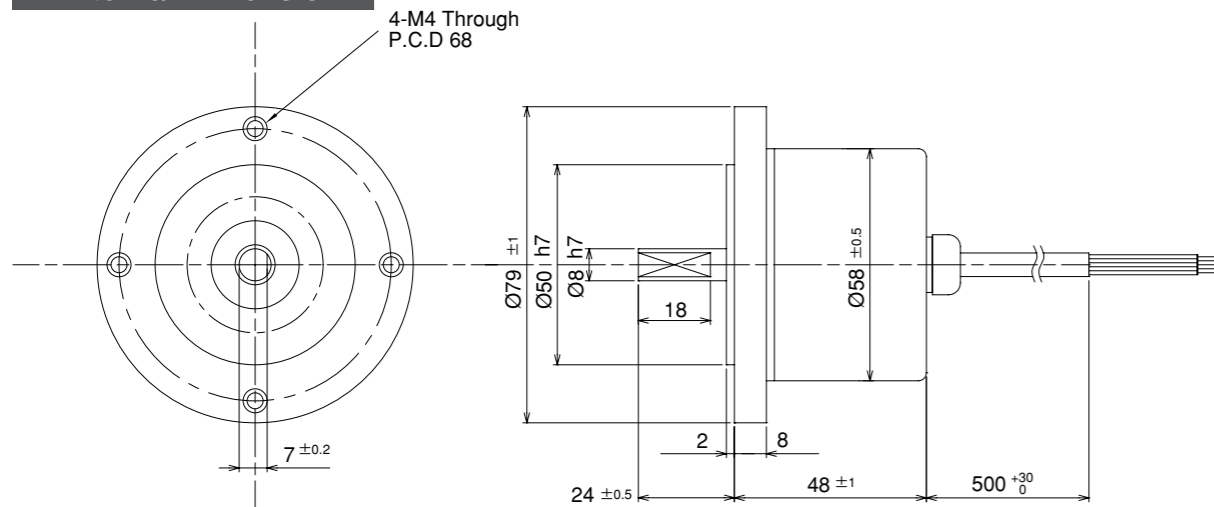

Output Circuit

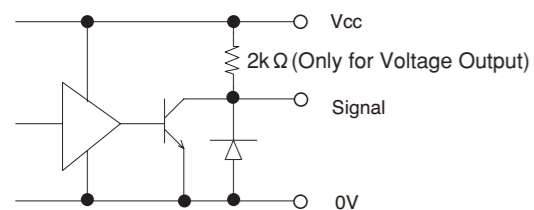

Electrical Spec

TYPE	1	2	2M	1C	2C	2MC	1HC	2HC	2MHC
Power Supply(Vcc)	DC4.5~13.2 V						DC10.8~26.4 V		
Current Consumption	80 mA Max			60 mA Max					
Output Voltage	“H”		Vcc-1V Min			—			
	“L” ※1		0.5 V Max						
Maximum Sink Current	20 mA								
Rise & Fall Time	1 μs Max								
Maximum Frequency Response	200 kHz								
Withstanding Voltage of Output Tr.	—						50 V Max		

※1) at Maximum Sink Current

Wave Form

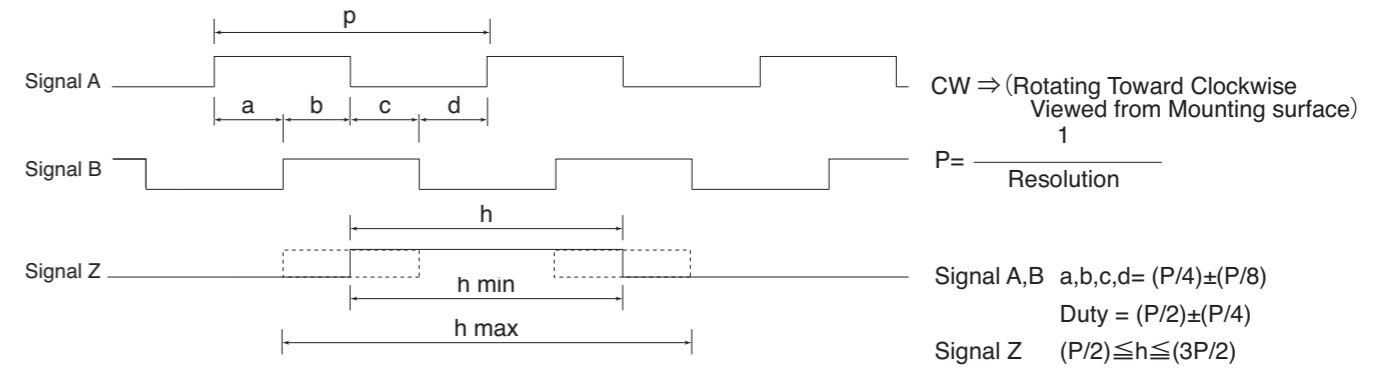

Electrical Connections

Color	Signal
Red	Power Supply(Vcc)
Black	0V
Green or Blue	Signal A
White	Signal B
Yellow	Signal Z
Shield	NC

Mechanical Spec

Starting Torque	19.6x10 ⁻³ N · m Max
Angular Acceleration	1x10 ⁵ rad/s ²
Shaft Loading	Thrust 29.4N
	Radial 49N
Moment of Inertia	4x10 ⁻⁶ kg · m ²
Maximum Permissible Speed	6000min ⁻¹
Net Weight	500g Max

Environmental Spec

Operating Temperature	- 10°C ~ + 70°C
Storage Temperature	- 30°C ~ + 80°C
Humidity	RH 85% Max No Condensation
Vibration	10~55Hz / 1.5mm X, Y, Z Each 2h
Shock	490m/s ² , 11ms X, Y, Z Each 3 times